



## FEATURES:

1. PI (proportional plus integral) control action provides accurate, stable and comfortable temperature control.
2. Compatible with series 70 direct-coupled damper / valve actuator like ML7161, ML7174, N20010, S10010, M7410E, ML7420, ML7421, ML7425, ML7984, etc.
3. Backlit LCD to display both setting and measured value.
4. Adjustable Zero Energy Band, On/Off Differential, Proportional Band and Temperature Offset.
5. Analog output can be forced manually to be convenient for installation & commissioning.
6. Optional 2 to 10Vdc or 4 to 20mA direct acting and reverse acting analog output.
7. Selectable internal and external temperature sensor.
8. Wide temperature control range (-20 to 110 °C by using external temperature sensor) is suitable for extreme temperature control such as steam and ice water.
9. Watch Dog Timer: to resume the controller from hanging condition.
10. Brownout effect to avoid malfunctioning and care on power ON and power OFF.
11. Pluggable terminal block allows pre-wiring outside of the controller.
12. Compact size and slim design provide elegant and attractive modern style appearance.

## APPLICATION:

This standalone micro-controller based LCD temperature controller provides proportional plus integral (P+I) and on/off temperature control for commercial Heating, Ventilating & Air Conditioning System such as Hydronic Heating, Air Handling Unit, Heat Exchanger or Condensing Tower.

This controller has a modulating analog 2 to 10Vdc or 4 to 20mA output and a 2A on/off output to realize various optional control functions including cool/heat changeover, heat/cool sequence control, emergency interlocking and auto-alarming control.

## Table of Contents

Application.....	1
Features.....	1
Specification.....	2
Dimensions, Installation & Wiring Terminals.....	3
Control Operation.....	4
Installer SetUp.....	10

## SPECIFICATIONS:

**IMPORTANT:** The specifications given in this publication do not include normal manufacturing tolerances. Therefore, this unit may not exactly match the listed specifications. Also, this product is tested and calibrated under closely controlled conditions and some minor difference in performance can be expected if those conditions are changed.

**MODEL:** T279811000

Control Performance: This controller provides 4 to 20mA or 2 to 10Vdc Proportional plus Integral modulating control and 4(2) A On/Off control.

**INPUTS:**

- 1) Analog - 1 No. (Only PT1000)
- 2) Digital - 1 No. (Dry Contact)

**OUTPUTS:**

- 1) Analog - 1 No.
- 2) Digital - 1 No.

**SETPOINT RANGE:**

- 10-50°C (internal temperature sensor)
- 20-110°C (external temperature sensor)

**POWER SUPPLY:** AC24V ±20%, 50/60Hz, 2 VA.

**ANALOG OUTPUT:**

- 2 to 10Vdc OR
- 4 to 20mA.

**DIGITAL OUTPUT:**

2A, 24Vac

**MOUNTING:** Direct wall mounting with standard electrical mounting box.

**TERMINALS:** Plug-in screw terminals are suitable for 1.5 square mm wire.

**OPERATING AMBIENT:**

0-50°C, 5-80%RH.

Shipping & Storage:

-20 - 45°C, 5-95%RH

**ACCURACY:**

< / = +/- 0.3°C

**REMOTE SENSOR:** RTD

PT1000.

Maximum 15m cable length

(line resistance < 4.5? )

Enclosure: ABS Plastic, 2-piece. (IP30)

**OPERATING PARAMETER:**

See TABLE 2 for installer selections.

Parameter	Selection
Zero Energy Band	1.5 or 3.0°C
On/Off Differential	0.5 to 3.0°C (0.5°C step change)
Proportional Band	2.0 to 19.0°C (0.1°C step change)
Offset	-3.0 to 3.0°C (0.5°C step change)
Set Point Definition	Heating, Cooling, H/C midpoint, Heating/Alarming or Cooling/Alarming.
Main Sensor	Remote or Internal

**ACCESSORIES:**

Duct Mount Remote Sensor PT1000.

DIN Class B.

Model # RSPT1000

Probe Length: 300mm

(to be ordered separately)

**DIMENSIONS:**

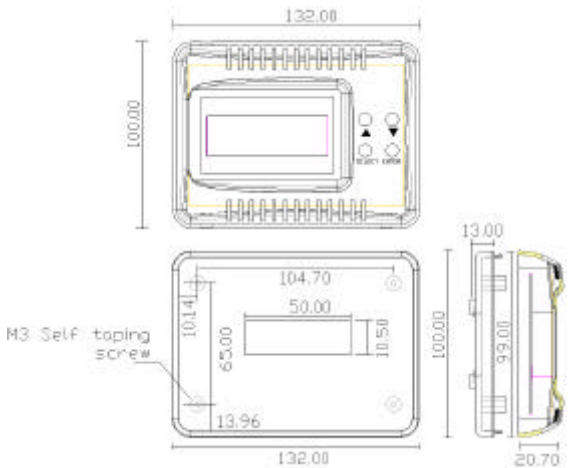

**WIRING TERMINAL:**

1	2	3	4	5	6	7	8
---	---	---	---	---	---	---	---

- 1 & 2 – Relay Output
- 3 – 0Vac
- 4 – 24Vac
- 5 – Digital Input
- 6 – Analog output 2...10Vdc OR 4...20mA
- 7 & 8 – PT1000 Remote Sensor

**INSTALLATION:**

The controller can be installed in any position on a flat surface using electrical box. To measure room temperature by internal sensor and choosing wall mounting method, it is recommended to be installed 1.5m (about 5 ft.) above the floor in the area at average temperature conditions. For all kinds of mounting method, the product must be installed in an area with good air circulation.

Do not install the controller where it may be affected by:

1. Draughts or dead air spots behind doors and in corners.
2. Hot or cold air from ducts.
3. Radiant heat from sun or appliances.
4. Concealed pipes and chimneys

## **CONTROL OPERATION:**

### **Input1 –Remote Temperature Sensor**

The controller has an integral sensing device mounted internally. It is also possible to install a remote room or duct return sensor at different locations. See wiring diagram.

**Note#1:** The remote sensor should be PT1000 (Refer Accessories)

### **Input2- Emergency Input**

Input2 is to connect with an On/Off dry contact for system error or emergency interlock control. If the contact is open, the controller will automatically close all output (or open to the maximum position in reverse mode) and cut off the power. The controller can only be restarted manually.

**Note#2:** If you don't want to use the interlock function/emergency input please use a jumper wire to connect input2 (terminal no.5) and neutral port (terminal no.3), see wiring diagram.

### **Output1-Modulating Analog Output (2 to 10Vdc or 4 to 20mA)**

Output1 is modulating 2 to 10Vdc or 4 to 20mA. It can be selected by Selector switch. The output signal in normal mode (2 to 10Vdc or 4 to 20mA) or reverse mode (10 to 2Vdc or 20 to 4mA) is selectable.

### **Output2- On/Off digital Output (2A, 24Vac)**

Output2 is digital output with 24VAC 2A Contact rating, nominal capacity. It provides On/Off control for electric heater, on/off valve actuator or fan etc.

Output2 can provide limitation control through presetting a separate temperature limitation.

**Heat / Cool Changeover of Output1**

Output1 is suitable for Heat/Cool changeover (manually) control in 2pipe AHU, Zoning control or Hydronic Heating application. Wiring connection is shown in fig. With cooling or heating selected, the user set point (SP) will be positioned at the middle of proportional band. The output percentage is proportional to the temperature measured and decided by proportional band. The proportional band can be set from 2.0°C to 19.0°C. The control logic is seen in Diagram 1.

Diagram 1:

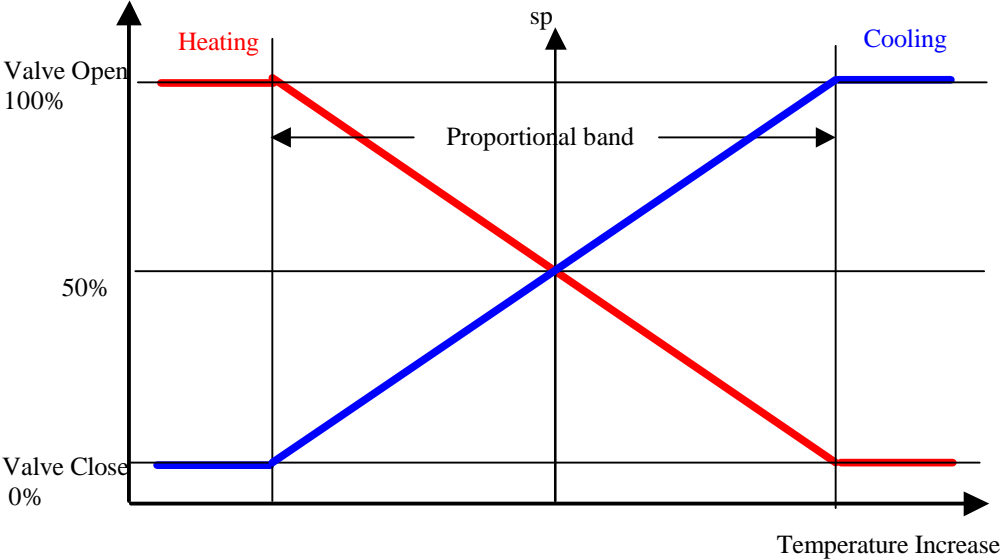

## Wiring Diagram

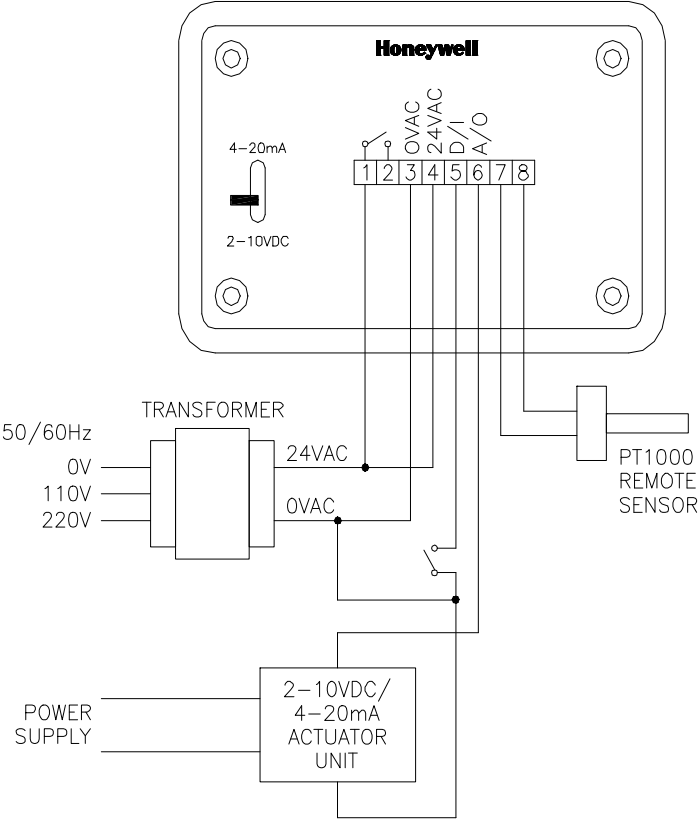

**Heating + Cooling Sequence control with Zero Energy Band**

This kind of control requires Zero Energy Band (Z-Band). Z-Band is pre-set. For control purpose, the zero energy band is centered on the user set point (SP), so its value defines the effective heating (H SP) & cooling (C SP) set points. The cooling set point (C SP) will be positioned on the right side of Z-Band & the heating set point (H SP) on the left side of Z-Band. Z-Band can be set as 1.5°C or 3.0°C. Any change of set point will cause both heating and cooling set points to change in parallel. Either output1 or output2 can be used for cooling or heating control. The control logic is seen in Diagram 2 and3.

**Diagram 2: Heating + Cooling Sequence Control.**

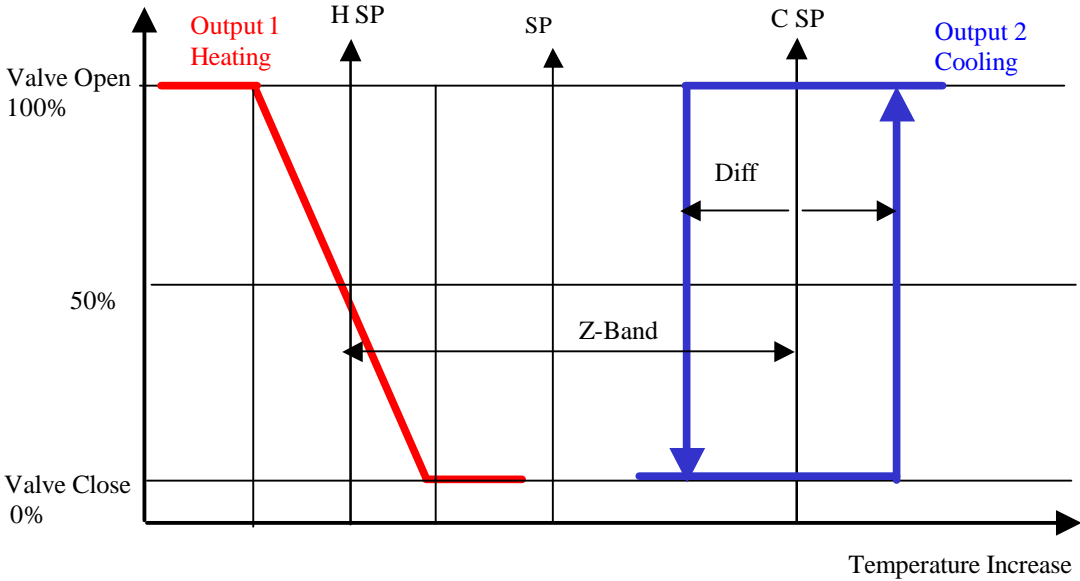
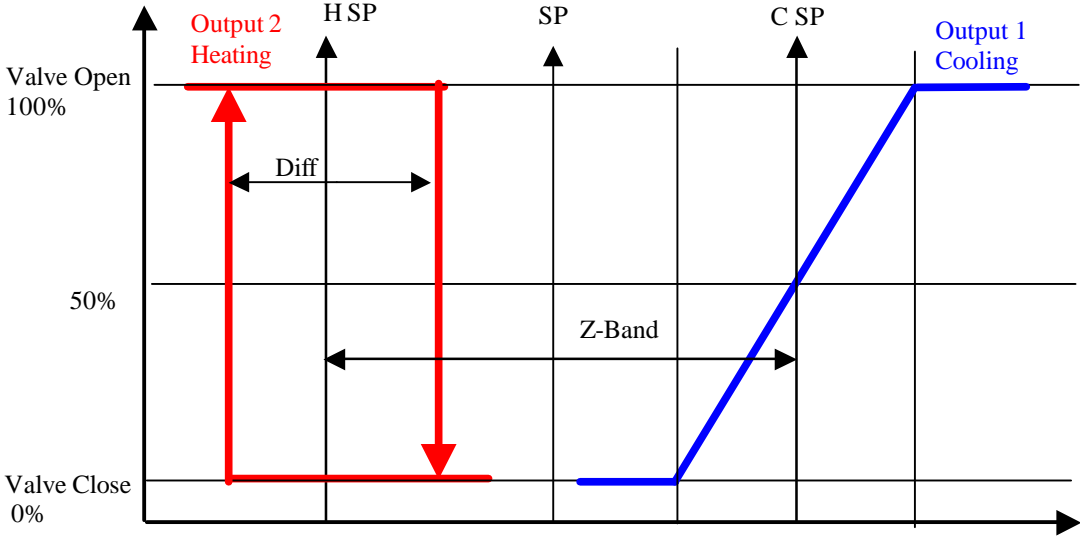

Diagram 3: Cooling + Heating Sequence Control.





## Heating/Cooling + Temperature Limitation Control

Output2 can be used for temperature limitation control. To select this function, 2 temperature set points must be pre-set. One is in the mid of proportional band of output1 (C SP / H SP) as main setting temperature. The second one is the temperature limitation of heating or cooling (A SP). In this mode if the measured temperature is higher (in heating mode) or lower (in cooling mode) than temperature limitation, output2 will close and output an alarming signal. The control logic is seen in Diagram 4 and 5.

Diagram 4: Cooling + Temperature Limit Control.

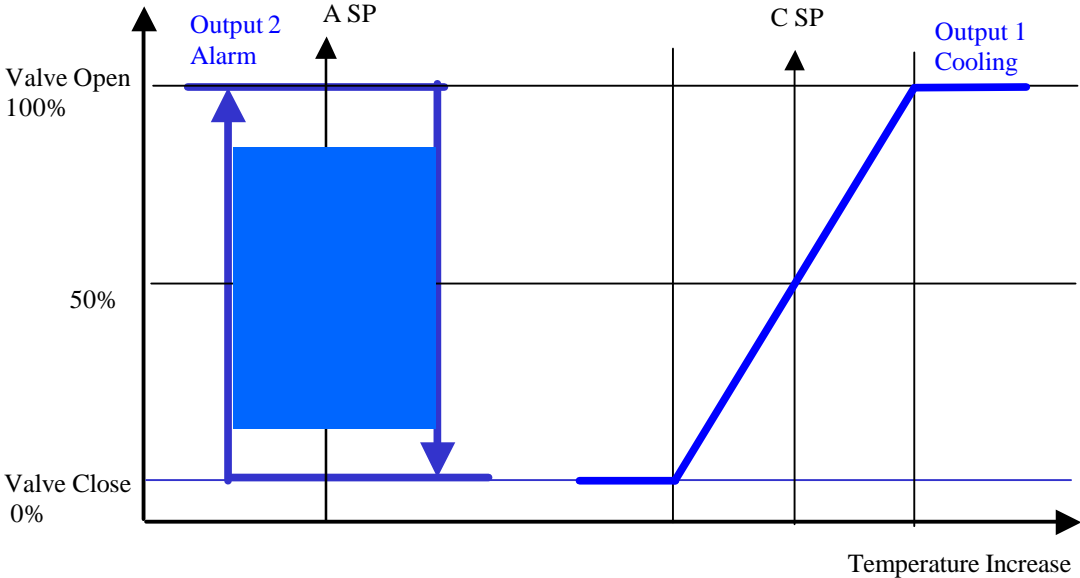

**Diagram 5: Heating + Temperature Limit Control.**

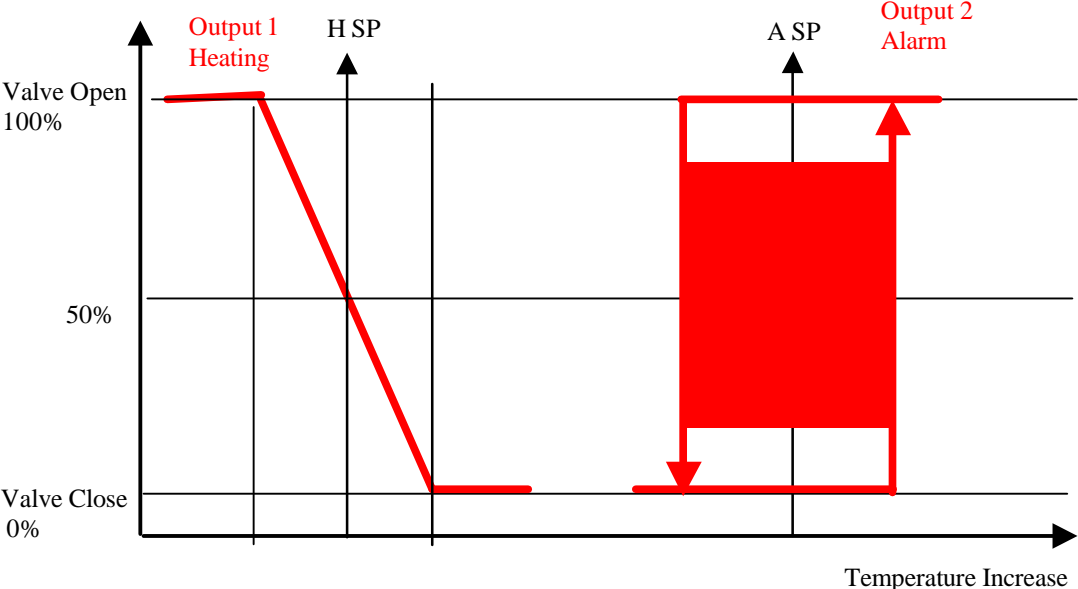

**Wiring Diagram**

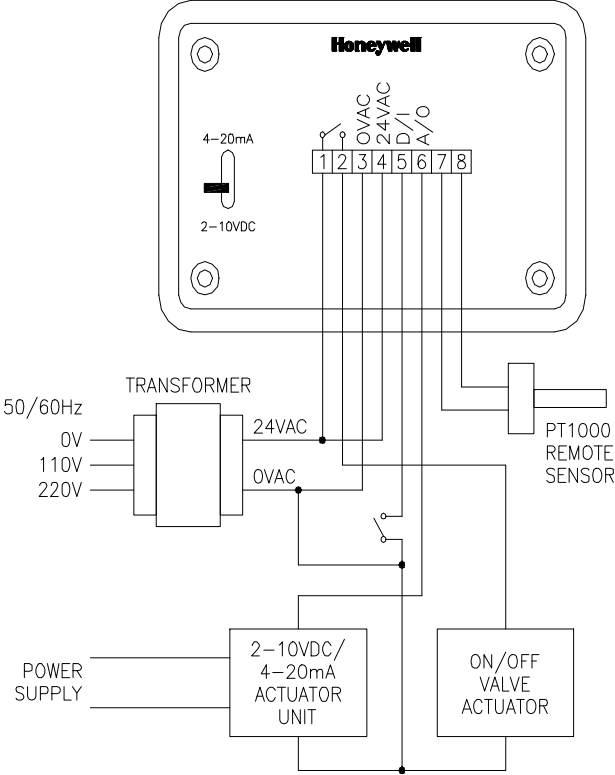

### Installer Set-Up:

1. Power ON/OFF :
- Connect the main power. Display will show “TATA Honeywell”, as shown in fig.1, for 5 Sec. Then display will show the Process value (PV) and Set point (SP) as shown in fig.2

	T	A	T	A		H	o	n	e	y	w	e	l	l	

Fig. 1

2. Set Point configuration (SP):
- Press ▲ key one time to step up the set point value by 0.1°C. If ▲ pressed continuously for more than ten steps then the value will increment by the step of 1.0°C up to 60.0°C (for internal sensor) or 110.0°C (for external sensor). Release ▲ key to stop the increment of temp set value.
  - Press ▼ key one time to step down set point value by 0.1°C. If ▼ pressed continuously for more than ten steps then the value will decrement by the step of 1.0°C up to 10.0°C (for internal sensor) or -20.0°C (for external sensor). Release ▼ key to stop decrement of temp set value.
  - Press “ENTER” key to save the set value.

	P	V		:					3	0	.	2	°	C
	S	P		:					1	9	.	0	°	C

Fig. 2

3. Zero Energy Band setting:
- Press “SELECT” to choose “Zero Energy Band Setting”, the display will show as in fig.3
  - Press ▲ key one time to switches from 1.5°C to 3.0°C.
  - Press ▼ key one time to switches from 3.0°C to 1.5°C.
  - Press “ENTER” key to save the set value.

	P	V		:					3	0	.	2	°	C
	Z	-	B	A	N	D				3	.	0	°	C

Fig. 3

#### 4. Differential setting:

- Press “SELECT” to choose “Differential Setting”, the display will show as in fig.4
- Press ▲ key one time to step up the differential setting by 0.5°C, it will stop incrementing at 3.0°C. The range is 0.5 to 3.0 °C.
- Press ▼ key one time to step down the differential setting by 0.5°C. It will stop decrementing at 0.5°C. The range is 3.0 to 0.5 °C.
- Press “ENTER” key to save the setting value.

	P	V		:						3	0	.	2	°	C
	D	I	F	F							1	.	0	°	C

Fig. 4

#### 5. Proportional Band Setting:

- Press “SELECT” to choose “Proportion Band Setting”, the display will show as in fig.5
- Press ▲ key one time to step up the Proportional band by 0.1°C. If ▲ pressed continuously for more than ten steps then the value will increment by the step of 1.0°C up to 19.0°C. Release ▲ key to stop the increment of the value.
- Press ▼ key one time to step down Proportional Band by 0.1°C If ▼ pressed continuously for more than ten steps then the value will decrement by the step of 1.0°C up to 2.0°C. Release ▼ key to stop the decrement of the value.
- Press “ENTER” key to save the setting value.

	P	V		:						3	0	.	2	°	C
	P	-	B	A	N	D				1	0	.	0	°	C

Fig. 5

#### 6. Offset Setting:

- Press “SELECT” to choose “Offset Setting”, the display will show as in fig.6
- Press ▲ key one time to step up Offset by 0.1°C. If ▲ pressed continuously for more than ten steps then the value will increment by the step of 1.0°C up to 3.0°C. Release ▲ key to stop increment of the value. The range is -3.0 to 3.0 °C.
- Press ▼ key one time to step down Offset by 0.1°C. If ▼ pressed continuously for more than ten steps then the value will decrement by the step of 1.0°C up to -3.0°C. Release ▼ key to stop increment of the value. The range is 3.0 to -3.0 °C.
- Press “ENTER” key to save the setting value.

	P	V		:						3	0	.	2	°	C
	O	F	F	S	E	T				-	1	.	0	°	C

Fig. 6

## 7. Mode Setting:

- Press “SELECT” to choose “MODE Setting”, the display will show as in fig.7
- Press ▲ key one time to step up. The total number of modes is 6. It will stop incrementing at last mode i.e. H/AL mode.

MODES:	Output 1 function:	Output 2 function:
COOL	Cooling	No Function
HEAT	Heating	No Function
C/H	Cooling	Heating
H/C	Heating	Cooling
C/AL	Cooling	Low Temp. limit Alarm
H/AL	Heating	High Temp. limit Alarm

- Press ▼ key one time to step down. The total number of modes is 6. It will stop decrementing at first mode i.e. COOL mode.
- Press “ENTER” key to save the setting value.

P	V	:							3	0	.	2	°	C
M	O	D	E						C	O	O	L		

Fig. 7

## 8. Sensor setting :

- Press “SELECT” to choose “Sensor Setting”, the display will show as in fig. 3
- Press ▲ key one time to switches from INT to EXT.  
INT : Internal sensor  
EXT : External sensor
- Press ▼ key one time to switches from EXT to INT.
- Press “ENTER” key to save the setting value.

P	V	:							3	0	.	2	°	C
S	E	N	S	O	R				I	N	T			

Fig. 8

9. Reverse Action Setting :

- Press “SELECT” to choose “Reverse Setting”, the display will show as in fig. 9
- Press ▲ key one time to switches from OFF to ON.  
 OFF : Output1 in normal mode, i.e. 2 - 10Vdc or 4 - 20mA  
 ON : Output in reversing mode, i.e. 10 - 2Vdc or 20 - 4mA.
- Press ▼ key one time to switches from ON to OFF.
- Press “ENTER” key to save the setting value.

	P	V		:						3	0	.	2	°	C
	R	E	V	E	R	S	E				O	F	F		

Fig. 9

10. Display Setting :

- Press “SELECT” to choose “Display Setting”, the display will show as in fig.10
- Press ▲ key one time to switches from OFF to ON.  
 OFF : Normal mode, as shown in fig. 2.  
 ON : Percentage mode, output1 is percent value (2Vdc or 4mA – 0% & 10Vdc or 20mA – 100%) as shown fig.11.
- Press ▼ key one time to switches from ON to OFF.
- Press “ENTER” key to save the setting value.

	P	V		:						3	0	.	2	°	C
	D	I	S	P	L	A	Y				O	F	F		

Fig. 10

	P	V		:						3	0	.	2	°	C
	A	0		:									9	1	%

Fig. 11

11. Manual Setting:

- Press "SELECT" to choose "Manual Setting", the display will show as in fig.12
- Press ▲ key one time to switches from OFF to ON.  
OFF: Manual OFF  
ON : Manual ON
- Press ▼ key one time to switches from ON to OFF.
- Press "ENTER" key to save the setting value.
- If manual on, the display will show as in fig.13

P	V		:						3	0	.	2	°	C
M	A	N	U	A	L						O	N		

Fig. 12

P	V		:						3	0	.	2	°	C
A	0		:									9	1	%

Fig. 13

- If manual ON, press ▲ key one time to step up the display value by 1%. If ▲ pressed continuously for more than ten steps then the value will increment by the step of 1.0% up to 100%. Release ▲ key to stop the increment of value.
- If manual ON, press ▼ key one time to step down the display value by 1%.
- If ▼ press continuously more than ten steps then the value will decrement by the step of 1.0% up to 0%. Release ▼ key to stop the decrement of value.
- After 90 minutes of manual ON operation the controller will return to manual OFF mode automatically.

12. F1 Setting :

- Press "SELECT" to choose "F1 setting", the display will show as in fig.14
- Press ▲ key one time to step up the Integral time by 0.1Sec. If ▲pressed continuously for more than ten steps then the value will increment by the step of 1.0Sec. up to 60.Sec. Release ▲key to stop the increment of value.  
The range is 0.1 to 60-Sec.
- Press ▼ key one time to step down the Integral time by 0.1Sec. If ▼pressed continuously for more than ten steps then the value will decrement by the step of 1.0Sec. up to 0.1Sec. Release ▼ key to stop the decrement of value. The range is 60 to 0.1Sec.
- Press "ENTER" key to save the setting value.
- This value setting shows how long the output1 will update the output value

P	V		:						3	0	.	2	°	C
F	1	(	I	)					1	.	0	S	E	C

Fig. 14

### 13. F2 Setting :

- Press “SELECT” to choose “F2 setting”, the display will show as in fig.15
- Press ▲ key one time to step up the Alarm Set point by 0.1°C. If ▲ is pressed continuously for more than ten steps then the value will increment by the step of 1.0°C up to 60.0°C (for internal sensor) or 110.0°C (for external sensor). Release ▲ key to stop the increment of value.
- Press ▼ key one time to step down the Alarm set point by 0.1°C. If ▼ pressed continuously for more than ten steps then the value will decrement by the step of 1.0°C up to 10.0°C (for internal sensor) or -20.0°C (for external sensor). Release ▼ key to stop decrement of value.
- Press “ENTER” key to save the setting value.

P	V	:							3	0	.	2	°	C
F	2								3	0	.	0	°	C

Fig. 15

### Default Setting:

Setting Parameters	Default Value
Z-BAND	1.5°C
DIFF	0.5°C
P-BAND	2.0°C
OFFSET	0°C
MODE	COOL
REVERSE	OFF
DISPLAY	OFF
MANUAL	OFF
SP	21°C
F1 (I)	15 SEC
ALARM (F2)	30°C
OUTPUT	2 to 10Vdc

**IMPORTANT:** Before setting, please check the following points.

1. Inspect the controller visually & check the push button before connecting the main power.
2. There should not be any abnormal phenomena or obvious shipping damage.
3. Check the Selector Switch & make sure that the switch is set at the right position.



Environmental & Combustion Controls  
**Honeywell Automation India Limited**  
56 & 57, Hadapsar Industrial Estate,  
Pune – 411 013, India.  
Phone: (91) 20 5603 9400  
Fax: (91) 20 5603 9979

Subject to change without notice. Printed in India.